

INSTALLATION AND OPERATION MANUAL

ARM-4073 AUTOMATIC REPRESSURE MODULES

SYSTEM CONCEPT

When not transferring fuel, the pressure in the underground closed piping system of a gasoline station may fall due to thermal contraction of the fuel within the line. This condition may create problems during future dispensing operations. The ARM-4073 Automatic Repressure Module ensures line pressure by periodically starting the submersible pump (turbine) to repressurize the line.

Figure 1 illustrates the wiring schematic of the system's control circuits. The diagram shows the connection of the circuits, but should not be interpreted as illustrating the relative size and location of the components. Figure 2 provides dimensional information for the module.

OPERATION

An ARM Module contains two timer circuits which operate in sequence. The first determines the pump running time. The second determines the delay time — the amount of time between pump operations. The following statements outline the operation of the ARM Modules.

1. With power applied, the module is active and performs its timing functions. The pump timer is the first to operate following the application of power. Following the completion of the pump cycle, the delay timer determines the elapsed time to the next pump cycle.
2. There is a small switch module located in the center of the circuit board. This module contains five miniature switches which are used to program the timers. Refer to Table 1 for the switch setting associated with the pump timer. Refer to Table 2 for the switch settings associated with the delay timer.
3. The timers operate asynchronously in relationship to dispensing authorization signals. That is, the timing sequence does not monitor dispensing operations and therefore the module may energize the pump contactor during a dispensing operation. This will not create a conflict with dispensing.

CONTROLLER LABELING

The following information is provided on the control unit's label.

- Controller name, model and serial numbers
- Voltage, current and load specifications
- Reference to the installation control drawing
- Manufacture's name and telephone number

The installer should be familiar with the information presented on the label.

ENCLOSURE AND MOUNTING

The module is designed for operation in a non-hazardous environment such as an equipment room. Holes are provided in the base for mounting the unit. Two holes are provided for the connection of ½" conduit fittings. A hole plug is provided for closing an unused conduit hole.

ELECTRICAL CONNECTIONS

It is important to properly connect the phases of the power system to prevent damage to the system. The following statements will assist in the proper connection of the ARM module.

1. The ARM-4073 may be powered from either a 115 VAC or 230 VAC source. Power source selection is made using shunt jumpers located on the bottom of the circuit board. The circuit board must be removed from the housing to access the shunts.

The unit is initially configured for a 115 VAC source and is shipped with two shunts each shorting a pair of power terminals. To configure the unit for a 230 VAC source remove both shunts and reinstall one of the shunts so that it is shorting the center pair of power terminals.

2. Authorization signals are generally powered from a 115 VAC source. Because this signal is derived from one of the phases of the power mains, there should be zero volts between the signal side of the contactor's coil when it is powered and one phase of the power mains. Using a voltmeter, determine which phase exhibits this condition.

Note that the source of the authorization control signal is not always apparent. It could be derived from a source which does not exhibit the characteristics noted in the previous paragraph. It is the responsibility of the installer to determine the appropriate signal which must be switched by the ARM.

3. Connect terminals L1 and L2 on the ARM to the selected power source. Refer to Figure 1.
4. Connect terminal K2 on the ARM to the signal side of the contactor's coil.
5. Connect terminal K1 on the ARM to the power phase or source determined in step 2.

EMERGENCY SHUT-OFF

When installing new equipment, it is important to maintain the integrity of the emergency shut-off system. It is the responsibility of the installer to develop an installation which provides for proper emergency shut-off function. A review of Figure 1 provides the following insights:

- If the shut-off system breaks power at the mains, voltage will be removed from both the pump and the ARM. This type of system will not be affected by installation of the module as shown in the schematic.
- If the shut-off only breaks the authorization signal, voltage will not be removed from either the pump or the ARM. If the module is installed as shown in the schematic, the repressure sequence will not be interrupted. This will result in unexpected pump operation. To provide a proper shut-off function the voltage to K1 must be from a source which is interrupted by the shut-off system.

POWER ON-OFF SWITCH

At certain times of the year when the thermal contraction of fuel is not interfering with proper operation of the distribution system it may be appropriate to disable the repressure module. A power switch is provided for this purpose, and is located on the side of the unit next to one of the two hole plugs.

With the slider positioned toward the hole plug, power is applied to the module. With the slider positioned away from the whole plug, power is removed from the module. The cover does not need to be removed in order to operate this switch.

MEASURING SYSTEM BLEED-BACK

When under pressure all closed piping systems exhibit an elastic response that will force fuel from the line if an opening is provided. The volume of fuel forced from the line is dependent on a number of factors and must be measured for each installation. The selection of a delay time from Table 2 is dependent upon this volume.

The following statements outline a procedure for measuring the expelled volume which is referred to as *bleed-back*. This procedure assumes the use of the Vaporless Model LDT-890 Leak Detector Tester to perform this task.

The following procedure assumes no knowledge of the operation of the LDT-890 and therefore details each step of the process. The operation manual supplied with the LDT-890 provides additional information and should be consulted by the technician.

1. Power Off

Turn off the circuit breaker providing power to the product under test. This is done to prevent the accidental starting of the turbine while the line is open in the following steps.

Turn off the power switch on the ARM. The location and operation of this switch is described under Power On-Off Switch. The unit is turned off to prevent unexpected starting of the turbine while the following procedure is being conducted.

2. Install LDT-890 Test Unit

Select the dispenser at the highest point of the delivery system. If there is no elevation difference, select the dispenser farthest from the turbine.

Caution: Eye protection required during the calibration process.

3. Carefully remove the plug from the test port on the impact valve. There should still be pressure in the line.
4. Install the 18" whip hose supplied with the test unit. The application of thread sealing compound is recommended.
5. Connect the quick disconnect coupler on the hose from the test unit to the whip hose.
6. Set the test unit selector to the PRESSURE STEP TEST position.

7. Power On

Turn on the circuit breaker for the product under test.

8. System Purge

Authorize the dispenser. The turbine should start running. On the right-hand pressure gauge of the LDT-890, watch for the turbine to achieve operating pressure.

9. Check all connections for leaks. Correct any fault conditions.

10. With the large beaker (1000 ml) under the LDT-890 discharge hose, set the selector to the DISPENSER NOZZLE position. Purge the tester of air by allowing 800 to 1000 ml of fuel to flow into the beaker. After purging the LDT-890, set the selector to the PRESSURE STEP TEST position.

11. Purge the dispenser line by running several gallons of fuel into an approved safety container.

12. Bleed-Back Measurement

Remove the dispenser authorization. The turbine should stop running. Unless there are fault conditions such as a leak or significant thermal contraction, the line pressure should stabilize at 20 – 30 PSI for fractional horsepower turbines, or 20 – 40 PSI for high-capacity or high-pressure turbines.

13. With the large beaker under the LDT-890 discharge hose, carefully move the selector to the DISPENSER NOZZLE position. Fuel will begin to flow into the beaker. When fuel stops flowing, return the selector to the PRESSURE STEP TEST position.

14. Note the volume of fuel collected. This volume is referred to as *bleed-back*. Repeat the collection process several times to confirm the bleed-back volume.

Depending on the measured volume, the use of the small (150 ml) beaker may provide more accurate measurements. The averaging of several consecutive samples is necessary to accurately determine the bleed-back volume.

15. Delay Timer Programming

Referring to Table 2, select the volume in the left-hand column which first exceeds the measured bleed-back. The next four col-

umns indicate the required switch settings. The right-most column indicates the approximate time delay between pump cycles.

16. The *Time Delays* shown in Table 2 are the minimum values needed to allow the leak detector to reset to its leak sense position. Longer delay times are acceptable, however, these longer delay times will increase the frequency of false alarms due to thermal contraction.

17. Pump Timer Programming

Referring to Table 1, select the value in the right-hand column (30 or 70 seconds) which provides enough time for the turbine to repressurize the line from a zero pressure condition. The column to the left indicates the required switch setting for the selected operating time. Under normal conditions 30 second setting should be selected. If the line exhibits excessive bleed-back or extreme thermal contraction, then the 70 second setting may be selected.

18. Perform Leak Detector 3 GPH Test

This completes the bleed-back measurement procedure and set-up of the ARM Repressure Module. A 3 GPH test should now be completed.

LEAK DETECTOR TEST AT 3 GPH

Whether a new installation or the retrofit of an existing installation using VMI Leak Detectors, a leak test should be performed. This is done to insure that the VMI Leak Detector is operating normally and that the selected ARM delay time is long enough for the VMI Leak Detector to return to its reset position.

The following statements outline a procedure for testing the operation of the VMI Leak Detector. This procedure assumes the use of the Vaporless Model LDT-890 Leak Detector Tester to perform this task.

The following procedure assumes no knowledge of the operation of the LDT-890 and therefore details each step of the process. The operation manual supplied with the LDT-890 provides additional information and should be consulted by the technician.

1. Install LDT-890 Test Unit

If the LDT-890 has not been installed, follow steps 1 through 11 in the procedure outlined under Measuring System Bleed-Back.

2. Leak Calibration

With the large beaker (1000 ml) under the LDT-890 discharge hose, set the selector to the CALIBRATE GPH position. Fuel will begin to flow into the beaker.

3. The object of the next step is to calibrate the fuel flow from the test unit to the rate of 3 gallons per hour at 10 psi pressure at the discharge. This specification meets the requirements of the EPA regarding leak rate testing.
4. The procedure is simply stated at follows: Adjust the fuel flow using the left-hand knob labeled CALIBRATE ORIFICE. Adjust the pressure on the left-hand pressure gauge to 10 psi using the right-hand knob labeled CALIBRATE PRESSURE.

Turn the ORIFICE knob counterclockwise to increase flow and clockwise to decrease flow.

Turn the PRESSURE knob counterclockwise to reduce pressure and clockwise to increase pressure.

First adjust the flow using the ORIFICE knob and then adjust the gauge pressure using the PRESSURE knob. It is important to perform the procedure in this order.

5. Using the small beaker (150 ml) collect a sample of fuel over a 30 second interval. The flow is properly adjusted when 95 ml are collected in 30 seconds. This volume is equivalent to a rate of 3 gallons per hour at 10 PSI. Repeat the procedure outlined in step 4 until the correct volume of fuel is collected in the specified time.
6. Set the selector to the PRESSURE STEP TEST position and remove the dispenser authorization.

7. Reduce Line Pressure to Zero

With the large beaker under the LDT-890 discharge hose, set the selector to the DISPENSER NOZZLE position. Fuel will begin to flow into the beaker. After the reading on the right-hand pressure gauge falls to zero, set the selector to the PRESSURE STEP TEST position.

8. Read Operating Pressure

Authorize the dispenser. The turbine will start running. Watch for the turbine to

achieve operating pressure as seen on the right-hand pressure gauge. Note this pressure reading and then remove the authorization from the dispenser.

9. Reduce Line Pressure to Zero

With the large beaker under the discharge hose, set the test unit's selector to the DISPENSER NOZZLE position. Fuel will begin to flow into the beaker. After the reading on the right hand pressure gauge falls to zero, set the test unit's selector to the GPH TEST position and authorize the dispenser.

10. 3 GPH Leak Test

With the dispenser authorized, the turbine will start running. With the selector in the GPH TEST position a 3 gph leak has been introduced to the system. On the right-hand pressure gauge watch for the turbine to build pressure. If the mechanical leak detector is properly calibrated this pressure should not reach the normal operating pressure previously observed. Note this lower pressure value. Remove the authorization from the dispenser.

11. Reduce Line Pressure to Zero

Set the test unit's selector to the DISPENSER NOZZLE position. Fuel will continue to flow into the beaker. After the reading on the right-hand pressure gauge falls to zero, set the selector to the GPH TEST position and again authorize the dispenser.

12. Leak Test Confirmation

With the dispenser authorized, the turbine will start running. Again, note that with the selector in the GPH TEST position a 3 gph leak has been introduced to the system. Watch the right-hand pressure gauge as the turbine builds pressure. The pressure should build to the value noted in Step 10.

TECHNICAL NOTE — If the pressure indicated on the right-hand pressure gauge does not stabilize at the lower pressure, but rather steps through to the higher normal operating value, the leak detector has failed the leak test. Contact the factory for calibration information.

Turn the selector to the PRESSURE STEP TEST position. Following a short delay the pressure should step up to the value noted in

Step 8. This is the indication that the mechanical leak detector has properly transferred from its leak test position to its full flow position.

13. Auto-Repressure Test

Remove the dispenser authorization. With the large beaker under the discharge hose, set the selector to the DISPENSER NOZZLE position. Fuel will flow into the beaker. After the reading on the right-hand pressure gauge falls to zero, set the selector to the PRESSURE STEP TEST position.

14. Set the ARM power switch to the ON position (refer to Power On-Off Switch). The turbine will start running. Immediately return to the dispenser. On the right-hand pressure gauge of the LDT-890, verify that normal operating has been achieved. Set the selector on the LDT-890 to the GPH TEST position. This will introduce a 3 GPH leak to the system. Because the leak detector has already stepped through to its fully open position, nothing will change. This leak must be introduced to the system before the 30 second (or 70 second) pump timer has completed its timing cycle.

15. At the end of the pump timing cycle, the ARM will automatically turned off the turbine. On the right-hand pressure gauge of the LDT-890, verify that the pressure falls due to the 3 GPH leak. If the proper delay timer has been selected from Table 2, the pressure should fall to zero before the next automatic pump cycle is started.

16. At the end of the delay timing cycle, the ARM will automatically turn on the turbine. Pressure will begin to build, but will stop at the value observed in Step 10 indicating that the leak detector has found the 3 GPH leak. This successfully completes the ARM test.

17. Disconnect LDT-890 Test Unit

Turn off the appropriate power breaker. Turn off the ARM power switch.

18. With the large beaker under the LDT-890 discharge hose, set the selector to the DISPENSER NOZZLE position and bleed off fuel until the reading on the right-hand pressure gauge is zero.

19. Disconnect the quick disconnect coupler attaching the test unit to the whip hose.

20. Remove the whip hose from the test port and install the original plug. The application of thread sealing compound to the plug is recommended.

21. Full System Operation

Turn on the power switch on the ARM. Turn on the power breaker. This completes the test procedure. The system including the ARM Automatic Repressure Module is now fully functional.

TIMER SWITCH SETTINGS

Table 1 — Pump Timer Switch Settings

Switch Number	Pump Time
1	
OFF	30 seconds
ON	70 seconds

Table 2 — Delay Timer Switch Settings

Bleed-Back (ml)	Switch Number				Delay Time (minutes)
	2	3	4	5	
150	OFF	OFF	OFF	OFF	2.0
350	ON	OFF	OFF	OFF	4.5
550	OFF	ON	OFF	OFF	7.0
700	ON	ON	OFF	OFF	9.5
900	OFF	OFF	ON	OFF	12.0
1100	ON	OFF	ON	OFF	14.5
	OFF	ON	ON	OFF	17.0
	ON	ON	ON	OFF	19.5
	OFF	OFF	OFF	ON	22.0
	ON	OFF	OFF	ON	24.5

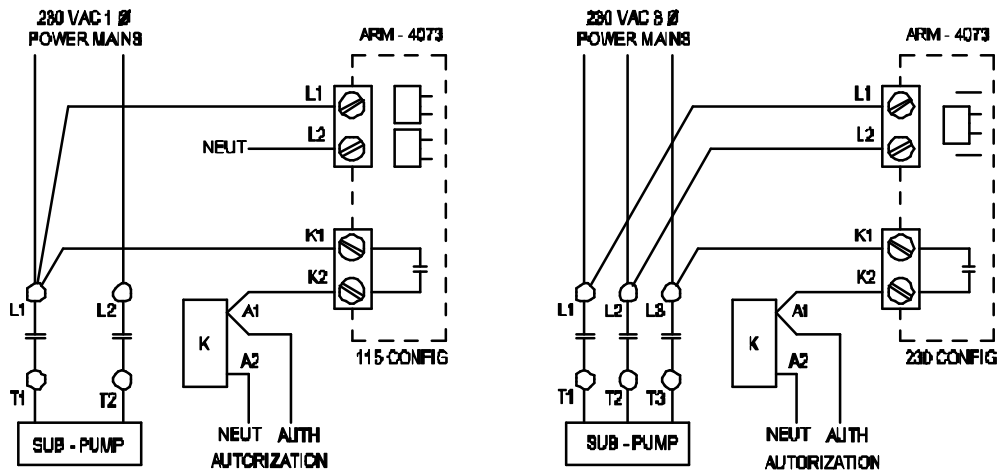

FIG 1 - Schematic 1595 - 009

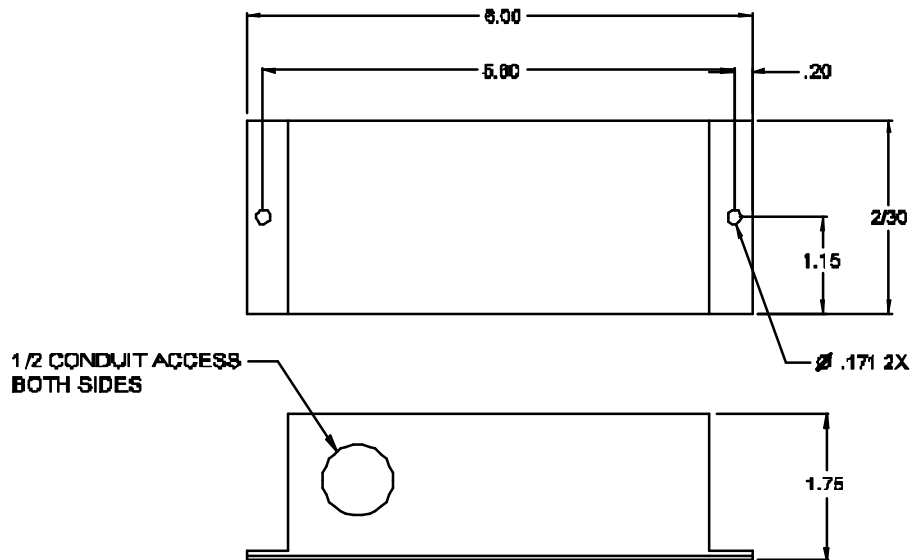

FIG 2 - ARM - 4073 Dimensions