



Test of the Vaporless Manufacturing ISM 4080 and ISM 4081

Final Report

PREPARED FOR:
Vaporless Manufacturing, Inc.

March 27, 2004

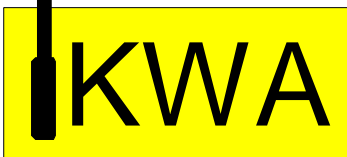

Ken Wilcox Associates, Inc.
1125 Valley Ridge Drive, Grain Valley, MO 64029, USA
Voice (816) 443-2494, Fax (816) 443-2495
E-mail info@kwaleak.com, Web <http://www.kwaleak.com>

Test of the Vaporless Manufacturing ISM 4080 and ISM 4081

Final Report

PREPARED FOR:
Vaporless Manufacturing, Inc.
8700 East Long Mesa Dr.
Prescott Valley, AZ 86314

March 27, 2004

Preface

This report presents the results of testing that was conducted on the Vaporless Manufacturing Model ISM 4080 Mechanical Leak Detection System. The results described in this report are based on data that were collected by Ken Wilcox Associates, Inc. to verify the manufacturer claim regarding the performance of this system. The testing was conducted and the report prepared by Wayne Hill. Questions regarding this report should be directed to Mr. Greg Young, Vaporless Manufacturing, at 800-367-0185.

Approved:

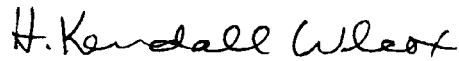
A handwritten signature in black ink that reads "H. Kendall Wilcox". The signature is written in a cursive style with a small dot above the letter 'i' in "Kendall".

H. Kendall Wilcox, President
March 27, 2004

Introduction

Vaporless manufacturing has produced a series of mechanical line leak detectors for several years. Recent improvements have been made by adding a switch to the mechanical leak detectors that automatically shuts down the submerged turbine pump (STP) when a 3 GPH leak is detected. The advantage to the modifications is that rather than staying in a slow flow mode for an indefinite period, the turbine will be shut down, greatly reducing the amount of fuel that could potentially be lost to the environment.

Description of the ISM/MLD System

VMI designed the ISM/MLLD combination to monitor a UST product line for pressure loss between dispensing cycles. If the product line is losing pressure, the VMI equipment restarts the submersible product pump, checking the line for a leak. If a leak is found, the equipment disables the submersible pump and closes an alarm contact to notify the station operator.

The loss of line pressure should cause the MLLD to reset to the line-test position. This condition is detected by a piston sensing switch attached to the MLLD. The switch is connected by wires to the ISM module. The ISM initiated pump start should cause the MLLD to do a 3GPH @ 10PSI leak check and repressurize the line if the pressure loss was due to thermal contraction. A leak of 3GPH @ 10PSI or greater should cause the MLLD to remain in the "restricted flow" position during the pump start. The ISM module translates the "restricted flow" position into a Low Pressure Alarm and shuts the submersible pump off.

The ISM module also checks the leak detector at authorization for dispensing fuel. If the leak detector is in the "restricted flow" position for fifteen (15) seconds after an authorization, the submersible pump is shut off and an alarm contact is activated.

VMI offers two models of the ISM, the ISM-4080 and 4081, the only difference being in the handling of sump switches. The sump switch is wired in series with the piston position switch for the 4080 series and either alarm will cause the pump to be disabled. The sump switch is wired into its own input circuit on the 4081 so that the module can differentiate between a product line leak and a sump alarm. This allows a warning rather than a pump shutdown for a sump alarm, permissible in some jurisdictions. The 4081 still shuts the product pump down for a product line leak alarm.

Because the equipment and circuitry for inputting and analyzing product line leaks and sump switches are the same for both the ISM-4080 and 4081 modules, they are both covered by this report. Full Details are found in the manufacturer's installation and operation manual.

Objectives

There were several objectives for this testing. These are:

1. To determine if the Vaporless Manufacturing, Inc (VMI) Mechanical Line Leak Detector (MLLD) with an attached piston sensing switch will detect a 3GPH @ 10PSI leak as required for all MLLDs.
2. To determine if the VMI ISM-4080 and 4081 Integrated Shutdown Module (ISM) shuts down the product pump if a 3GPH @ 10PSI leak is detected.
3. To determine if the VMI ISM-4080 and 4081 ISM will sense a sump alarm and shut down the product pump.

Test 1 Purpose:

To determine if the piston sensing switch attached to the MLLD interferes with the detection of a 3GPH @ 10PSI leak.

Test 1 Set-Up & Procedure

1. A Vaporless MLLD with attached sensor switch was installed in the leak detector port of a Red Jacket P75S1 pumping unit per "Test 1 Layout and Electrical Schematic" attached. The switch leads were not connected.
2. The pump was started with no leak, opening the MLLD for full flow.
3. The discharge valve was opened to purge the piping system of air.
4. A Ken Wilcox Associates LS2003 leak simulator was used to establish a 3GPH @ 10PSI leak into the piping system. An integral on-off valve was used to connect the leak to the piping system as needed.
5. The leak was connected to the line and the pump was turned off.
6. After line pressure reached 0PSI, the pump was restarted.
7. Reaction of the MLLD to the leak (restricted or full flow) was recorded.
8. The leak was disconnected and the MLLD allowed to reset to the open position.
9. The piping discharge valve was opened to allow product circulation for several minutes.
10. Steps 5-9 were repeated 6 times.

Test 1 Results

Trial #	Leak Rate	Reaction to Leak
1	3GPH @ 10PSI	Restricted Flow
2	3GPH @ 10PSI	Restricted Flow
3	3GPH @ 10PSI	Restricted Flow
4	3GPH @ 10PSI	Restricted Flow
5	3GPH @ 10PSI	Restricted Flow
6	3GPH @ 10PSI	Restricted Flow
7	3GPH @ 10PSI	Restricted Flow

Test 2 Purpose

To determine if the Vaporless MLLD with attached piston sensing switch and ISM-4080 module can detect a 3GPH @ 10PSI leak and disable the product pump.

Test 2 Set-Up & Procedure

1. Building on the previous test setup, the sensor switch leads, the ISM-4080 module, and the Red Jacket control box were connected per "Test 2 & 3 Layout and Electrical Schematic" attached. Only connections required for detection of the leak and pump control were made, i.e. no alarm outputs, etc., were connected.
2. The pump was started with no leak, opening the MLLD for full flow.
3. The discharge valve was opened to purge the piping system of air.
4. The LS2003 leak simulator was used to establish a 3GPH @ 10PSI leak into the piping system. An integral on-off valve was used to connect the leak to the piping system as needed.
5. The discharge valve was closed and the authorization switch toggled several times, ending up with the pump on.
6. The leak was connected to the line and the pump was turned off.
7. After line pressure reached 0PSI, the pump was restarted.
8. Reaction of the MLLD to the leak (restricted or full flow) was recorded.
9. Reaction of the pump to the authorization switch was recorded.
10. The leak was disconnected from the pipe line, the ISM-4080 was reset, the pump started, and the MLLD allowed to reset to the open position.
11. The piping discharge valve was opened to allow product circulation for several minutes.
12. Steps 5-9 were repeated 6 times.

Test 2 Results

Trial #	Authorizations	Leak	Leak Detected?	Pump Disabled?
1	3	3GPH	Yes	Yes
2	3	3GPH	Yes	Yes
3	3	3GPH	Yes	Yes
4	3	3GPH	Yes	Yes
5	3	3GPH	Yes	Yes
6	3	3GPH	Yes	Yes
7	3	3GPH	Yes	Yes

Test 3 Purpose

To determine if a sump switch attached to the ISM-4080 module will be detected and cause the pump to be disabled.

Test 3 Setup & Procedure

1. A sump switch was added in series with the leak detector sensor switch per “Test 2 & 3 Layout and Electrical Schematic” attached.
2. The authorization switch was toggled, turning the pump on and off.
3. While the authorization switch was in one of the two positions, the sump switch was activated, as in a sump alarm condition.
4. The status of the pump when the sump switch was activated was recorded.
5. The reaction of the ISM-4080 to the sump alarm was recorded.
6. The reaction of the ISM-4080 module in disabling the pump was recorded.
7. The ISM-4080 module and the sump switch were reset.
8. Steps 2-6 were repeated 6 times.

Test 3 Results

Trial #	Pump On/Off	Alarm Detected?	Pump Disabled?
1	On	Yes	Yes
2	On	Yes	Yes
3	Off	Yes	Yes
4	On	Yes	Yes
5	Off	Yes	Yes
6	Off	Yes	Yes
7	On	Yes	Yes

Conclusions

1. The Vaporless Manufacturing, Inc. attached sensor switch does not affect the MLLD’s ability to detect a 3GPH @ 10PSI leak.
2. The ISM-4080 disabled the pump when a 3GPH @ 10PSI leak was detected. The ISM-4081 module should do so by identical design.
3. The ISM-4080 disabled the pump when a sump switch alarm was detected. The 4081 module should also detect the sump switch by identical design and will enable an alarm but not disable the pump.

Test 1 Layout & Electrical Schematic
Vaporless Manufacturing ISM 4080 & Switch
Ken Wilcox Associates
3/24/04, WHill

Switch wires not
connected
during Test 1

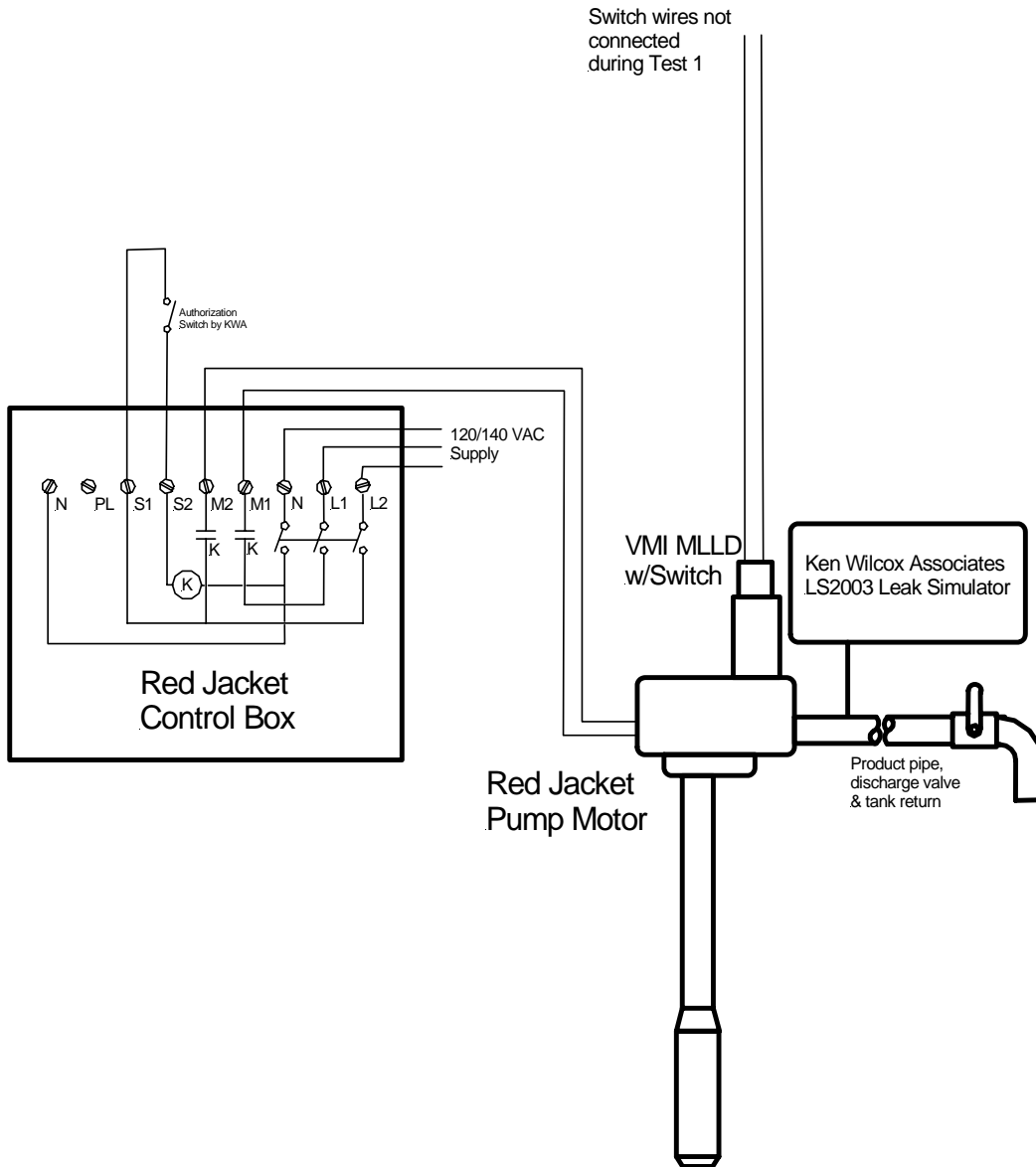

Test 2 & 3 Layout & Electrical Schematic
Vaporless Manufacturing ISM 4080 & Switch
Ken Wilcox Associates
3/24/04 W Hill

